

ECONOMICAL

# SINGLE ROLL

SIZE REDUCTION

# LUMP CRUSHER

## ◆ THE FIELDS OF APPLICATION

Single roll lump crushers Type 3111 are used for primary crushing in the chemical and coal industry. They are applied, for example, in the chemical industry to break down the soft to medium-hard lumps of raw material which are dispersed from the granulator to a final grain size of approx. 0–20 mm.

## ◆ THE MODE OF OPERATION

The main components of the machine consist basically of a housing, crusher roll and a crushing plate. The crusher is available in four standard sizes.

The roller width is determined according to the required capacity while maintaining a constant roller diameter. A continuous feeding spread over the whole width of the roll ensures a high capacity performance and reduces wear of the crushing rings and combs.

The crushing roll is driven by an electric motor with coupling and gears via V-belt.

## ◆ THE ADVANTAGES

- high output with a high reduction ratio
- wear-resistant crushing tools
- low maintenance requirements
- compact space-saving design
- low operating costs
- overload protection

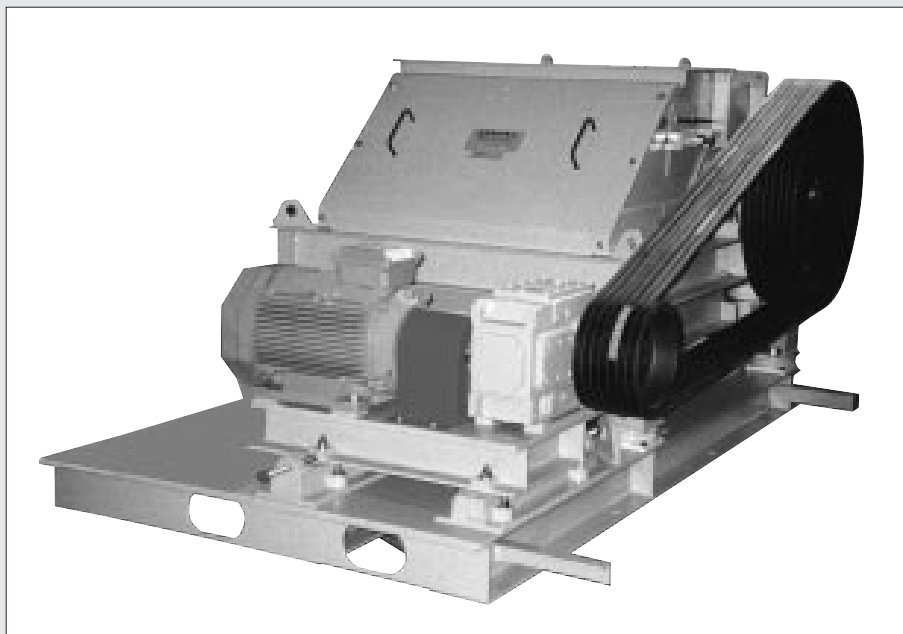

**AUBEMA**  
M A S C H I N E N M I T B I S S